

VIAVAC GBH-1800

For large and heavy glass elements









**VACUUM GLASS LIFTER
UP TO 1.800 KG**

VACUUM LIFTING
VIAVAC

In short

High performance device

The VIAVAC GBH is a multifunctional vacuum lifting device for large and heavy glass elements up to 1,800 kgs. The device can easily be assembled in 11 different configurations for installing different glass sizes. A quattro vacuum system provides optimum safety. Easy and secure manouvring of the glass elements is possible thanks to a 90° hydraulic tilting mechanism and a 360° electric rotary mechanism.

-  **Suitable for large glass elements**
-  **Tool-free (dis)assembly of the extensions**
-  **Quattro vacuum system**
-  **360° electric rotate mechanism / 90° hydraulic tilt mechanism**
-  **Easy to transport in frame**
-  **Two batteries with long operating time**

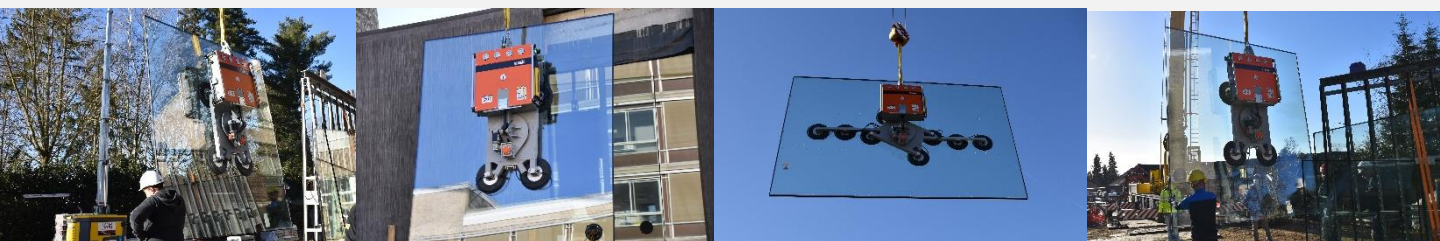

VIAVAC GBH-1800

Functionalities

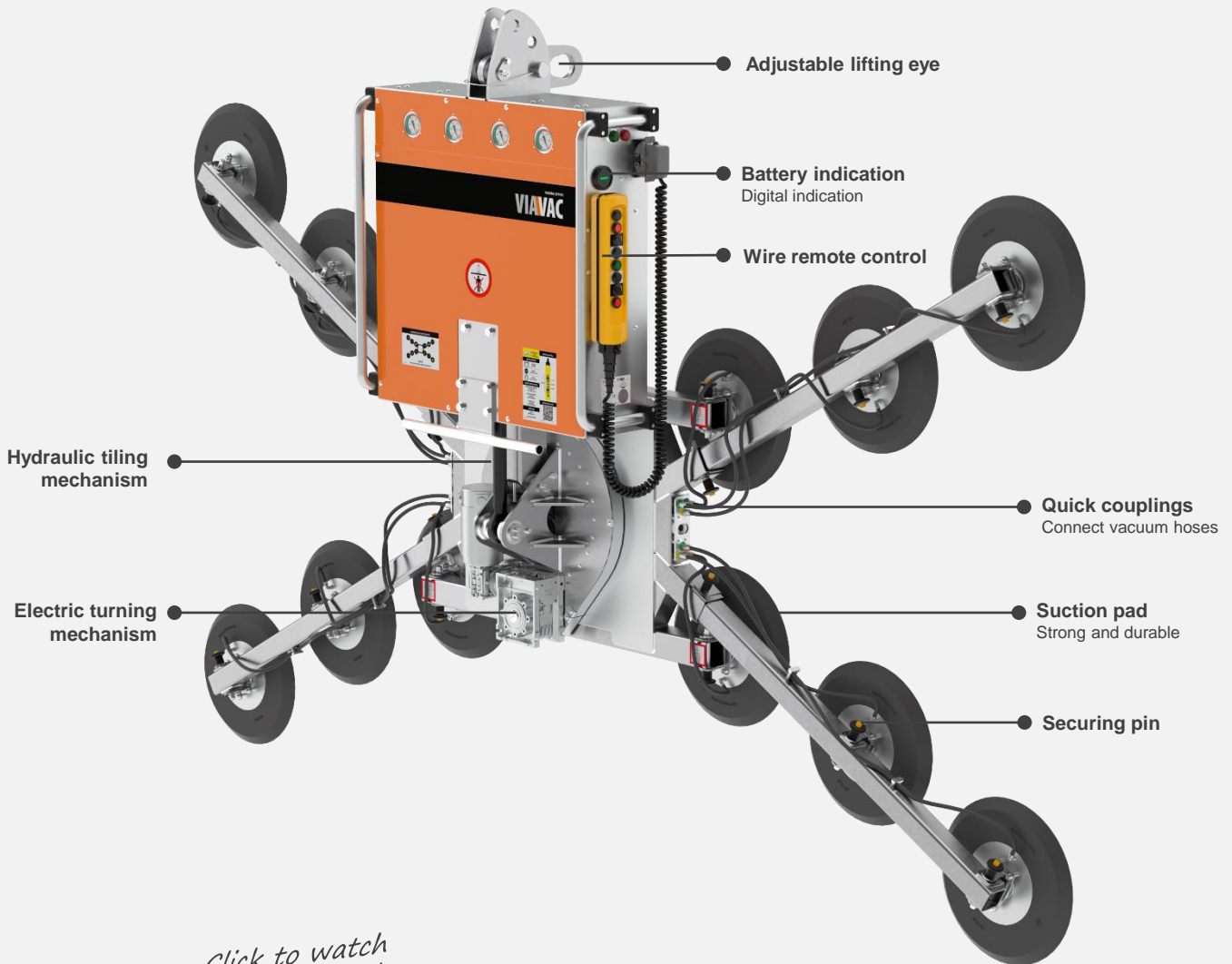

*Click to watch
the promo-video*

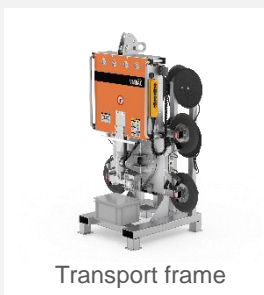

Transport frame

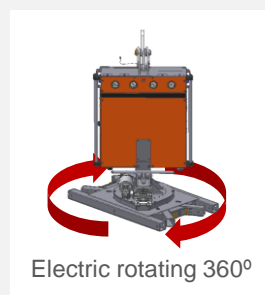

Electric rotating 360°



Hydraulic tilting 90°

Configurations

Flexibility with one device

1.800 kg



1.200 kg



600 kg



Options and accessories

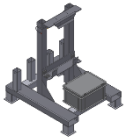

Transport frame

Robust transport frame for safely transporting and storing of the lifting device.



Radio remote control

(De)activates vacuum, tilting and rotating. Equipped with safety code for discharging.

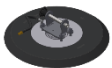

Suction pad

Type SP20 with diameter of 400 mm.



Protection cover

Solid protection cover with elastic for suction pad.



RAL colour of choice

Can be supplied in RAL colour of choice.
*May affect the delivery time.



References

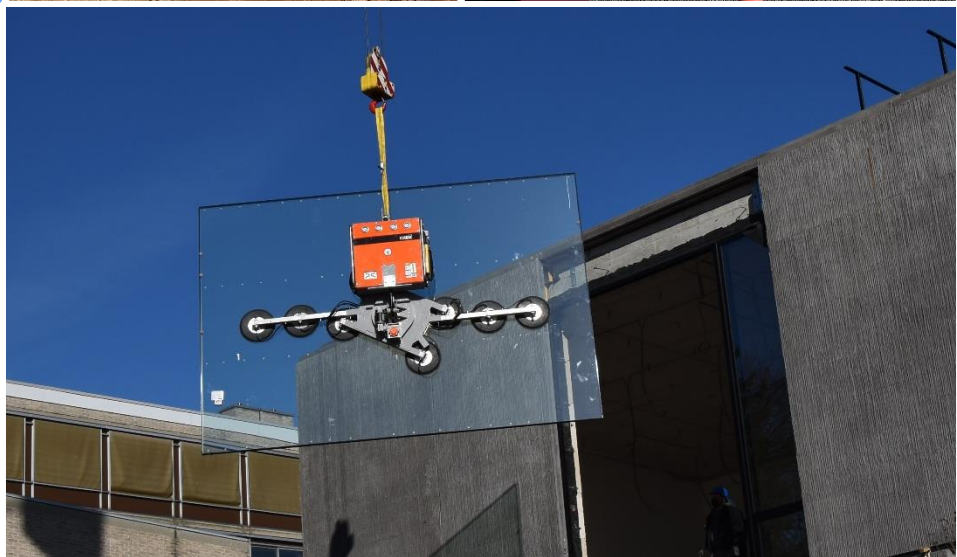
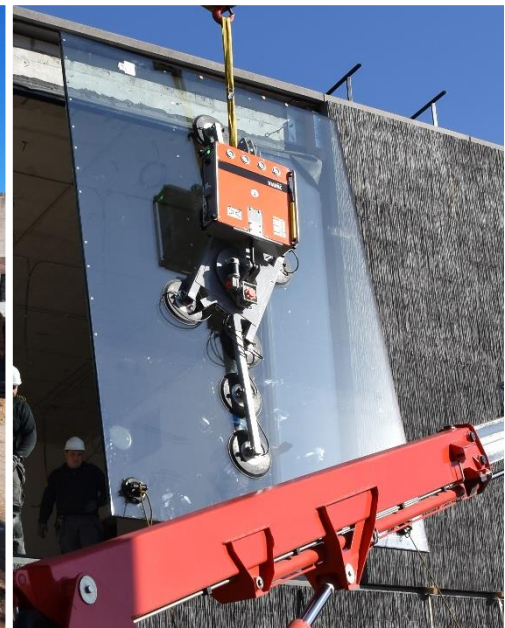

VIAVAC GBH-1800

Technical specifications

Functions

- 90° hydraulic tilting mechanism
- 360° electric turning mechanism
- Cable remote controle for suction, release, tilt and rotate.

For your safety

- Four independent vacuum circuits each with 2-fold safety margin
- Integrated vacuum gauges with red / green indication
- Audible and visible warning by low vacuum level
- Timely warning when battery is running low
- Vacuum buffer tanks with non-return valves
- Breather valve for quick release

Technical details

Vacuum system: Quattro circuit
 Battery: 2x 12V 60Ah
 Charging time approx. 5 hours

Configuration	4P-0E	8P-2E	12P-4E
Lifting capacity:	600 kg	1,200 kg	1,800 kg
Machine weight:	260 kg	295 kg	350 kg

Complies with European standard EN 13155.

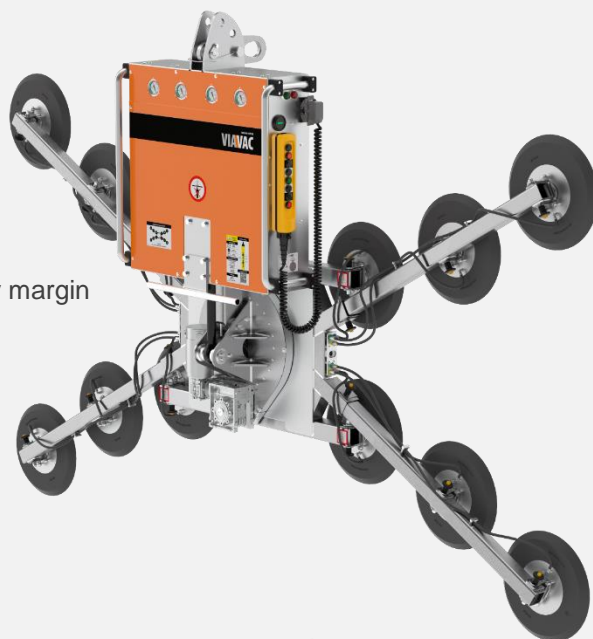

Optional
Radio remote control

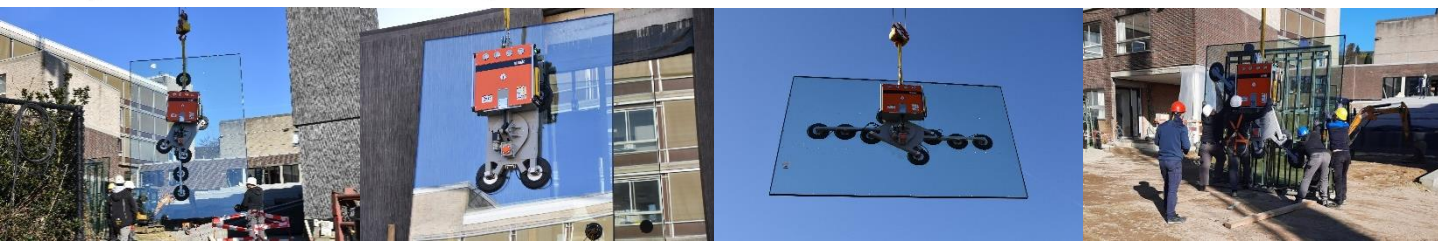
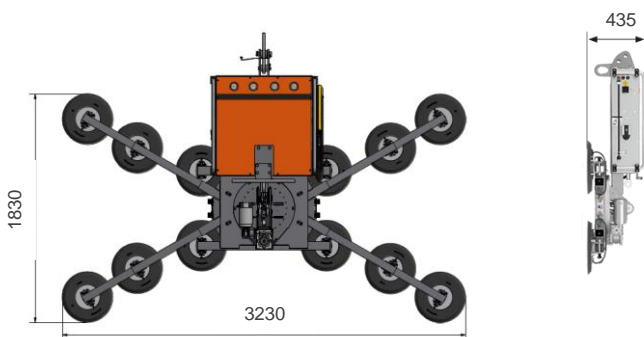

About VIAVAC

Company profile

VIAVAC is a Dutch manufacturer of vacuum lifters for the mounting of sandwich panels and glass elements. The VIAVAC vacuum lifters have been developed in-house. Started in 1995 and therefore already active for more than 25 years.

Rental, sales and service

Thanks to a large stock and good logistics, you can count on a quick delivery. In the unlikely event of a problem occurring during work, we will do everything in our power to help you as quickly as possible.

International network

Our vacuum lifting devices are used all over the world. We work with a large and growing international network of reliable distributors, resulting in VIAVAC users in more than 75 countries.

VIAVAC vacuum lifting BV

1^e Industrieweg 8
3411 MG Lopik
The Netherlands

+31 (0)348 449 660
info@viavac.com
www.viavac.com

