

# ROTA BOY

VACUUM LIFTING AND TURNING DEVICE FOR ROOF PANELS

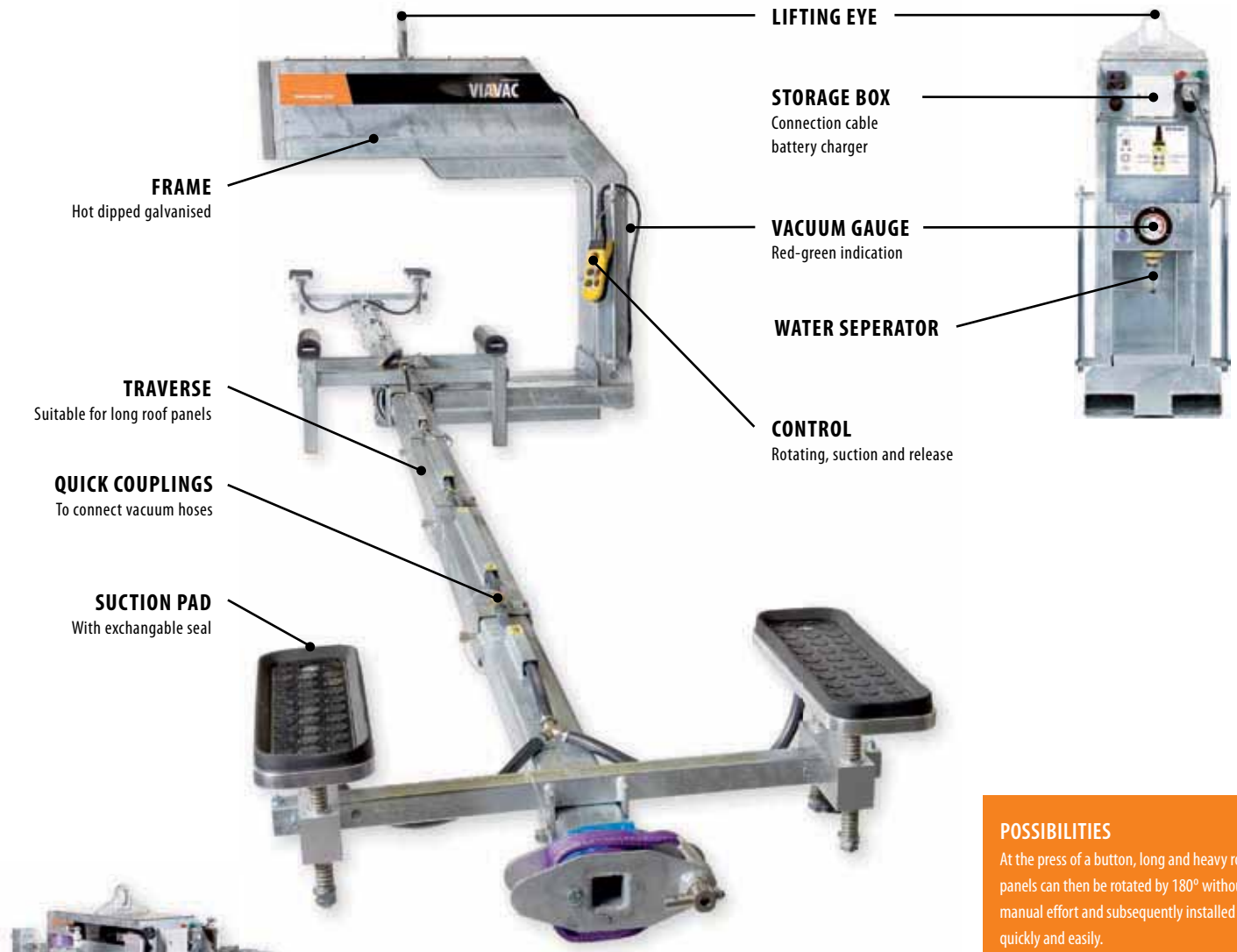

# ROTA BOY



## MODULAR EXECUTION POWERED BY INTERNAL, RE-CHARGEABLE BATTERY

COMPACT AND TRANSPORTABLE

### POSSIBILITIES

At the press of a button, long and heavy roof panels can then be rotated by 180° without manual effort and subsequently installed quickly and easily.

### SAFETY FEATURES

- Audible low vacuum warning
- Large vacuum buffer tank
- Low battery warning
- Secondary safety device

### SPECIFICATION

- Lift and turn capacity 350 kg
- Machine weight 500 kg



4 Cladding Services  
Gateway to Humberside Trading Estate,  
Gilberdyke, Brough.  
HU15 2TD

T : +44 (0)370 741 7600  
F : +44 (0)370 741 7601  
E : info@vaclifting.co.uk

**4**Cladding  
Services